



Part:	Velocity stack assembly
P/N:	SPSB-400/500
Model:	Kawasaki Ninja 400/500 (2018 - present)
Doc:	Assembly and installation instructions, v0.1

WARNING: For racing vehicle use only! Our products are intended to be used only on racing vehicles on closed courses and are not for use on public roads. It is the user's responsibility to ensure that all Spears enterprises LLC Design installation and assembly instructions are followed explicitly. Spears Enterprises LLC. Design recommends that installation be performed by a trained, professional technician. The User recognizes that any alteration or modification to any motorcycle and/or improper installation may increase the risk of serious injury, accident or death and may also render the motorcycle illegal for public road use.

<p>Parts included:</p> <ul style="list-style-type: none"> • 2x Snap Stacks™ velocity stacks • 2x Intake manifolds <p>Tools required:</p> <ul style="list-style-type: none"> • Phillips screwdriver • Dremel with Rotozip bit, or similar 	<p>Materials required:</p> <ul style="list-style-type: none"> • Cutting template & thumb tack (included) 	<p>Upgrade products if desired:</p> <ul style="list-style-type: none"> • Air filter upgrade: MWR race filter recommended (Part number SP02—400/500 MWR at www.spearsenterprises.com)
--	---	---

Ninja 400/500 Airbox Assembly

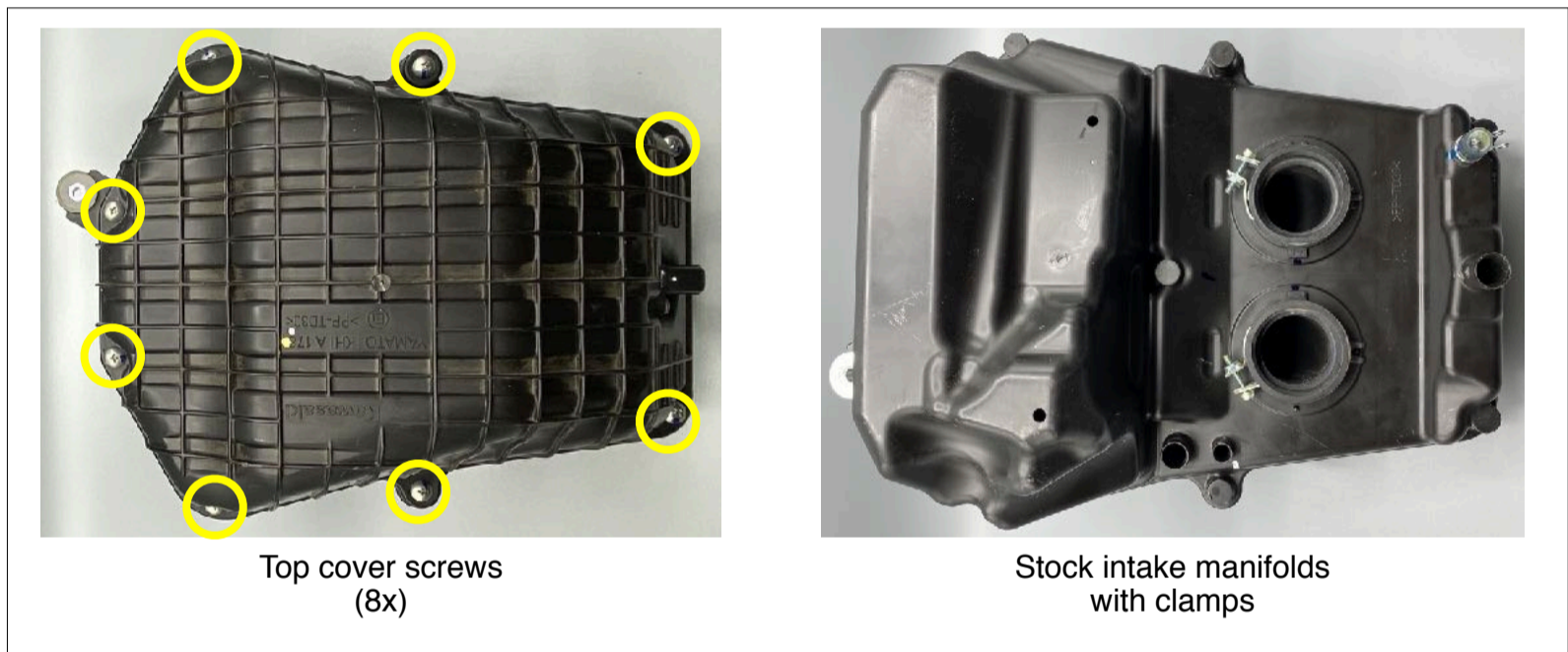

Top cover screws (8x)

Stock intake manifolds with clamps

Step 1: Remove the 8x top cover screws and the top cover, set aside. Remove the air filter, set aside. Remove stock clamps.

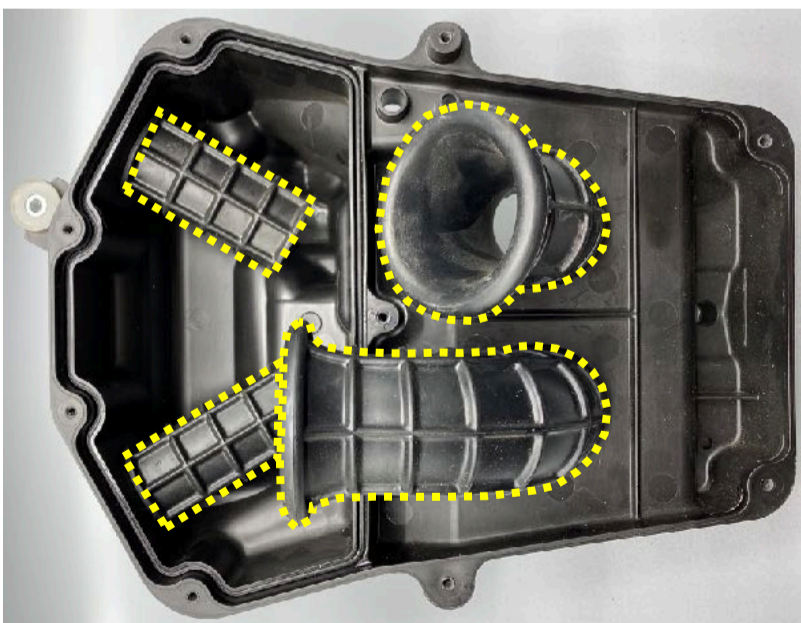

Step 2: Remove the stock velocity stacks and intake snorkels.



Figure 1: Cutting template held in place using the included thumb tack.

Step 3: Using the included thumb tack, attach the cutting template to the airbox (see Figure 1 above). Trace the template. Remove the thumb tack and template.

Part:	Velocity stack assembly
P/N:	SPSB-400/500
Model:	Kawasaki Ninja 400/500 (2018 - present)
Doc:	Assembly and installation instructions, v0.1

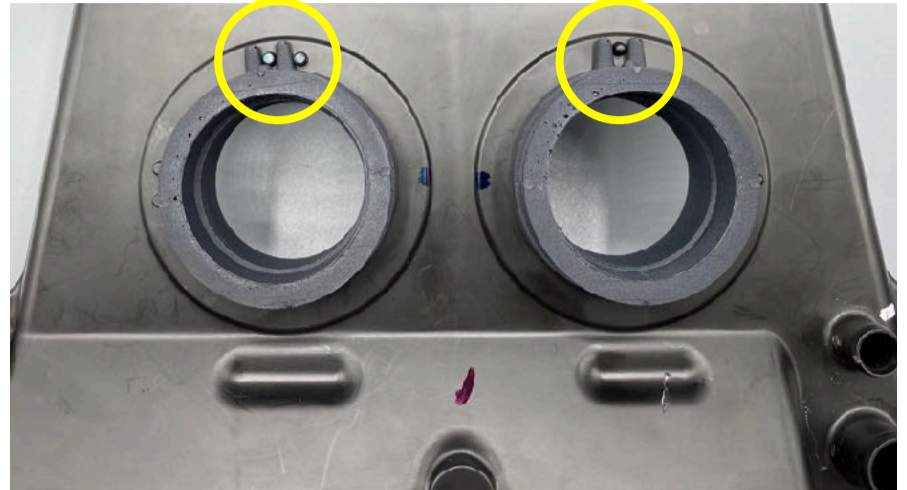

Figure 2: New manifold alignment tabs mated with the airbox alignment tabs.

Step 4: Cut along the trace line, using a Dremel with a Rotozip bit or similar is recommended. Clean the cut edges as well as the airbox to remove any loose debris.

Step 5: Install the new manifolds in the airbox, lining up the manifold alignment tabs and the airbox alignment tabs (see Figure 2 above).

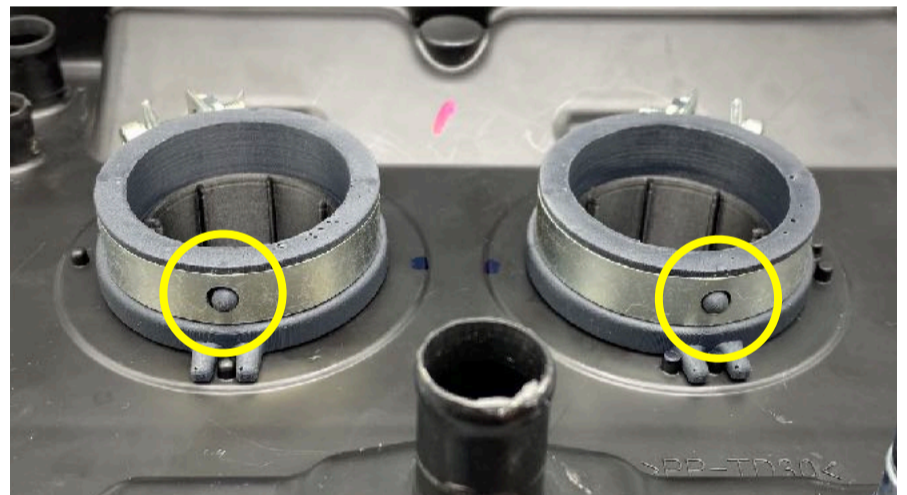
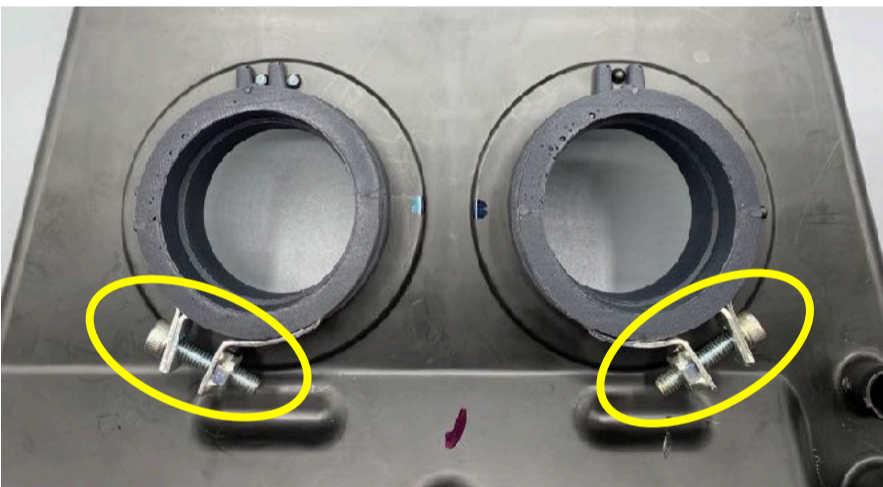

Figure 3: New manifold alignment tabs mated with the stock clamp holes.

Step 6: Re-install the stock manifold clamps, aligning the new manifold tabs with the stock clamp holes (see Figure 3 above).



Step 7: Install the Snap Stacks™ velocity stacks into the intake manifolds, be sure they are fully seated. Replace the air filter and top cover.