

Kawasaki Shifting Arm Assist Kit Ninja EX400 2018/2019

External Shift Mechanism

External Shift Mechanism Removal

- Remove:
Clutch (see Clutch Removal in the Clutch chapter)
- Remove the shift lever clamp bolt [A], and disconnect the shift lever [B] from the shift shaft.
- Remove:
OEM Circlip [C]
OEM Washer [D]
Special Tool - Outside Circlip Pliers

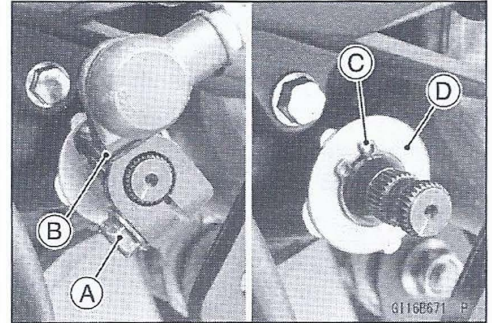

- Remove:
Shift Shaft Assembly [A]

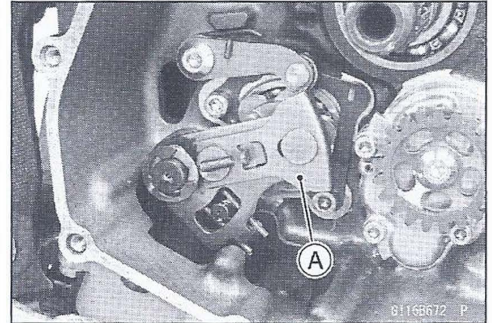

External Shift Mechanism Installation

- Once that you have removed the Shift Shaft Assembly [A] remove the OEM kawasaki .040 Washer/Shim and replace it with the new thinner washer from the Spears Racing kit.
- Install:
Shift Shaft Assembly [A]
○Fit the return spring pin [B] between the spring ends [C].
○Pull the shift mechanism arm [D], and hang it to the shift drum cam [E].
- Install Spears Racing Washer [A].
- Replace the circlip [B] with the new one supplied
Special Tool - Outside Circlip Pliers

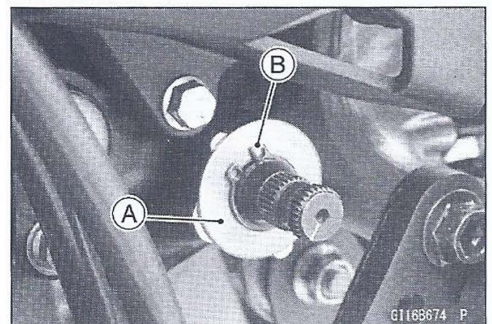
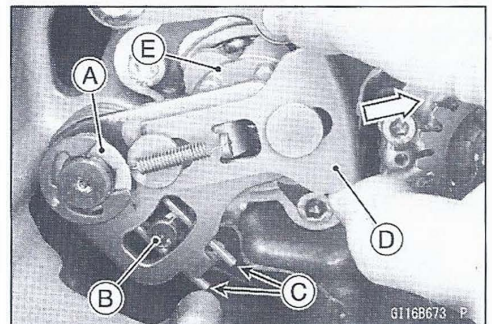
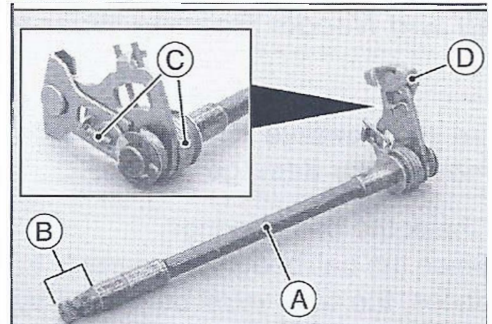

Fit the circlip into the groove of the shift shaft securely.



Spears Enterprises LLC/Spears Racing
15253 S Inheritance Way
Manteca Ca, 95336
Ph(209)923-4684